

Technical documentation

Technical documentation according to **Batteries Regulation 2023/1542, Article 17, Annex VIII, Part A, Module A - “Internal production control”, Clause 2:**

1. GENERAL DESCRIPTION AND INTENDED USAGE

Lithium-Ion rechargeable battery, consisting in Lithium Iron Phosphate (LiFePO₄) as cathode and carbon (graphite) as anode, with Lithium salts (such as LiPF₆) in an organic solution as electrolyte. Battery is equipped with overcharge BMS to protect the battery from overcharge. It is designed to supply the intended electric power in motor vehicles for SLI (Starting, Lightning or ignition) functions and can be used for auxiliary or backup purposes in vehicles, other means of transport or machinery.

Voltage/Chemistry/Application : 12V Li-Ion Marine & Leisure

2. CONCEPTUAL DESIGN, MANUFACTURING DRAWINGS AND SCHEMES OF COMPONENTS

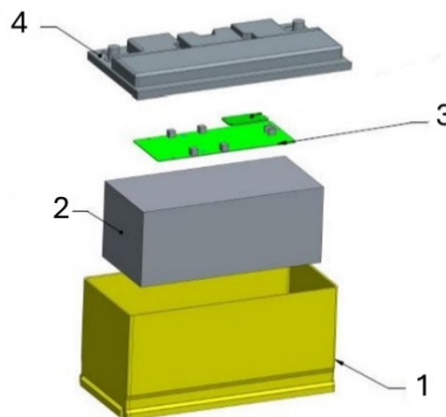

- 1. Container
- 2. Cells pack
- 3. BMS
- 4. Lid

3. DESCRIPTIONS AND EXPLANATIONS

No further documentation is needed to understand drawings and schemes. For any details concerning operation of the battery refer to safety instructions and user manual.

4. MARKING SPECIMEN (acc. to Article 13)

For a transition period (see Article 95 of the Battery Regulation), requirements from both - the Directive and the Regulation - apply in parallel.

The eco marking requirements – the crossed out dustbin, the recycling loop and the symbol to indicate the heavy metal content - and the restriction on mercury, cadmium had been transferred from the Directive into the Regulation.

The marking requirements are derived from

- Article 4, Article 21 and Annex 2 of the EU Battery Directive 2006/66 and
- Article 6, Article 13 and Annex 6 of the EU Battery Regulation 2023/1542

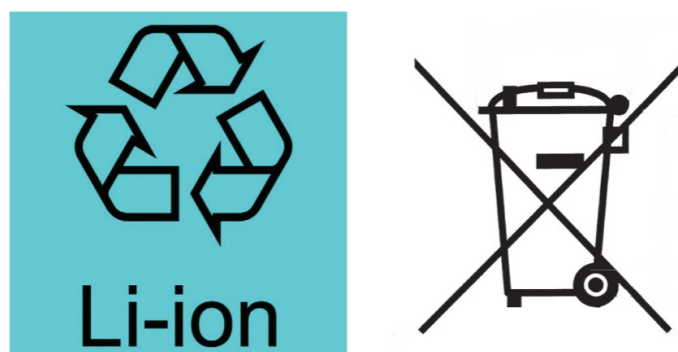

Figure 2 – Example of marking with symbol for separate collection according to Annex VI Part B

5. List of harmonised standards and common specification and other relevant technical specifications used for measurement or calculation purposes

No harmonized standards are available. Article 6 (restriction on substances) and Article 13 (labelling and marking of batteries) compliance requirements don't need specific measurements or calculations.

6. Description of the solutions adopted to meet the applicable requirements

- Restrictions on substances as per **Article 6 and Annex I**
 - Mercury and Cadmium content limits compliance is ensured by suppliers certifications
 - For Mercury² and Cadmium³ content limits compliance, in case of battery suppliers, reference requirements are stated in suppliers PPAP and Certificates of Compliance

- ² Mercury content limit in ppm is 5
- ³ Cadmium content limit in ppm is 20

7. Results of design calculations made and examinations carried out, and the technical or documentary evidence used

Article 6 (restriction on substances) and Article 13 (labelling and marking of batteries) compliance requirements don't need specific design calculations. Restricted substances examinations according to Article 6 are handled by incoming goods and suppliers certifications inspections

8. Test reports

- Article 6 compliance: Mercury and Cadmium content limits compliance is ensured by suppliers certifications
- Article 13 compliance: no testing is required to ensure compliance to requirements according to Article 13 (labelling and marking of batteries)

NOTES:

1. EXIDE Technologies decision making processes, innovation, development, industrialization and products quality are managed following risk management principles and procedures in accordance with EXIDE's certified compliance to ISO 9001 (clause 6.1) and to IATF 16949 (clause 6.2.1.1).
2. Batteries placed on the market or put into service by EXIDE, provided proper product handling and usage as intended/specified, do not present risks to human health, safety of persons, properties or environment